

CENTRAL MACHINERY

®

AIR FILTRATION SYSTEM WITH REMOTE CONTROL

Model 91393

ASSEMBLY AND OPERATING INSTRUCTIONS

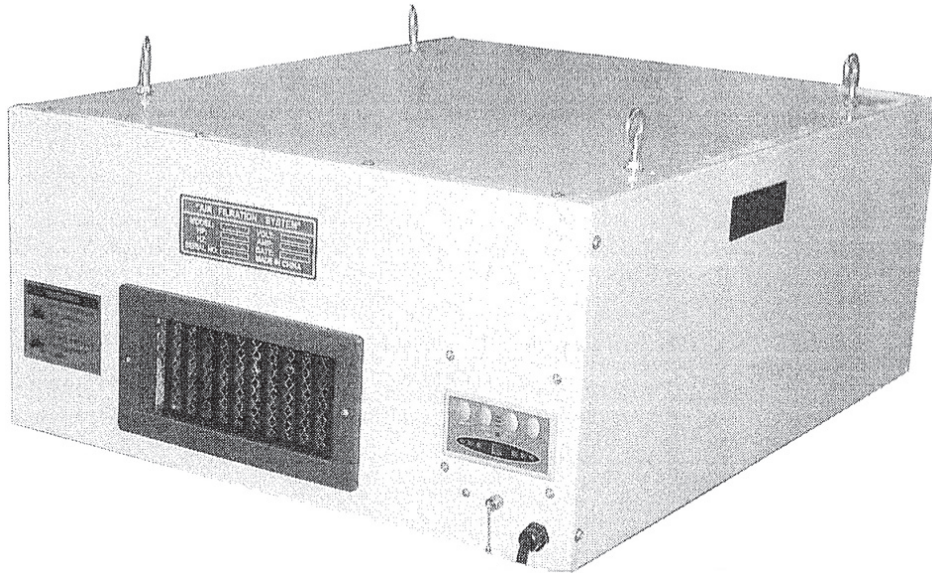

3491 Mission Oaks Blvd., Camarillo, CA 93011

Visit our Web site at: <http://www.harborfreight.com>

Copyright© 2004 by Harbor Freight Tools®. All rights reserved. No portion of this manual or any artwork contained herein may be reproduced in any shape or form without the express written consent of Harbor Freight Tools.

For technical questions, please call 1-800-444-3353.

PRODUCT SPECIFICATIONS

Motor	1/6 HP, 115 V, 60 Hz, 1 Phase
Overall Dimensions	30-1/8" x 24" x 12- 1/8"
Outer and Inner Filter	5 Microns
Noise	50-60 dB
Air Flow	High Speed - 360 CFM, Low Speed - 230 CFM
Weight	66 Lbs.
Power Cord	5' 3" L, 3-Prong, UL Listed
Remote Control	Uses 2 "AAA" Batteries (included)

SAVE THIS MANUAL

You will need this manual for the safety warnings and precautions, assembly, operating, inspection, maintenance and cleaning procedures, parts list and assembly diagram. Keep your invoice with this manual. Write the invoice number on the inside of the front cover. Keep this manual and invoice in a safe and dry place for future reference.

GENERAL SAFETY RULES



WARNING!

READ AND UNDERSTAND ALL INSTRUCTIONS
Failure to follow all instructions listed below may result in electric shock, fire, and/or serious injury.
SAVE THESE INSTRUCTIONS

WORK AREA

1. **Keep your work area clean and well lit.** Cluttered benches and dark areas invite accidents.
2. **Do not operate electric products in explosive atmospheres, such as in the presence of flammable liquids, gases, or dust.**
3. **Keep bystanders, children, and visitors away while mounting or maintaining the Air Filtration System.**

ELECTRICAL SAFETY

4. **Grounded products must be plugged into an outlet properly installed and grounded in accordance with all codes and ordinances. Never remove the**

grounding prong or modify the plug in any way. Do not use any adapter plugs. Check with a qualified electrician if you are in doubt as to whether the outlet is properly grounded. If the product should electrically malfunction or break down, grounding provides a low resistance path to carry electricity away from the user.

5. **Double insulated products are equipped with a polarized plug (one blade is wider than the other). This plug will fit in a polarized outlet only one way. If the plug does not fit fully in the outlet, reverse the plug. If it still does not fit, contact a qualified electrician to install a polarized outlet. Do not change the plug in any way.** Double insulation eliminates the need for the three wire grounded power cord and grounded power supply system.
6. **Avoid body contact with grounded surfaces such as pipes, radiators, ranges, and refrigerators.** There is an increased risk of electric shock if your body is grounded.
7. **Do not expose this product to rain or wet conditions.** Water entering an electric product will increase the risk of electric shock.
8. **Do not abuse the Power Cord. Never use the Power Cord to carry the product or pull the Plug from an outlet. Keep the Power Cord away from heat, oil, sharp edges, or moving parts. Replace damaged Power Cords immediately.** Damaged Power Cords increase the risk of electric shock.

PERSONAL SAFETY

9. **Stay alert. Watch what you are doing, and use common sense when operating a power product. Do not use a power product while tired or under the influence of drugs, alcohol, or medication.**
10. **Dress properly. Do not wear loose clothing or jewelry. Contain long hair. Keep your hair, clothing, and gloves away from moving parts.** Loose clothes, jewelry, or long hair can be caught in moving parts.
11. **Avoid accidental starting. Be sure the Power Switch is off before plugging in.**
12. **Use safety equipment. Always wear eye protection.** During installation and maintenance use non-skid safety shoes and ANSI approved safety goggles.

TOOL USE AND CARE

13. **Use the correct product for your application.** The correct product will do the job better and safer at the rate for which it is designed.
14. **Do not use the power product if the Power Switch does not turn it on or off.** Any product that cannot be controlled with the Power Switch is dangerous and must be replaced.
15. **Disconnect the Power Cord Plug from the power source before storing the system.**

16. **Store idle products out of reach of children and other untrained persons.** Products are dangerous in the hands of untrained users.
17. **Maintain products with care. Keep products clean.** Do not use a damaged product. Tag damaged products “Do not use” until repaired.
18. **Check for misalignment or binding of moving parts, breakage of parts, and any other condition that may affect the product’s operation. If damaged, have the product serviced before using.** Many accidents are caused by poorly maintained products.

SERVICE

20. **Product service must be performed only by qualified repair personnel.** Service or maintenance performed by unqualified personnel could result in a risk of injury.
21. **When servicing a product, use only identical replacement parts. Follow instructions in the “*Inspection, Maintenance, And Cleaning*” section of this manual.** Use of unauthorized parts or failure to follow maintenance instructions may create a risk of electric shock or injury.

SPECIFIC SAFETY RULES

1. **Maintain labels and nameplates on the Air Filtration System.** These carry important information. If unreadable or missing, contact Harbor Freight Tools for a replacement.
2. **Maintain a safe working environment.** Make sure there is adequate surrounding workspace. Always keep the work area free of obstructions, grease, oil, trash, and other debris. Do not use a power products in areas near flammable chemicals, dusts, and vapors. Do not use this product in a damp or wet location.
3. **If placing this Air Filtration System on a table or shelf, make sure that the machine is placed securely on a flat, level surface, capable of supporting the weight of the machine.**
4. **If attaching the Air Filtration System to a ceiling, make sure the machine is attached securely to joists capable of supporting the weight of the machine.**
5. **Make sure the Switch is in the “Off” position before plugging in the power cord.**
6. **Keep the Pleated Type Filter (1) and the 3-Pocket Type Filter (2) clean, in place, and in good working order.**
7. **Always unplug the Air Filtration System from its electrical outlet before performing any inspection, maintenance, or cleaning procedures.**

ADDITIONAL WARNINGS

GROUNDING

WARNING!

Improperly connecting the grounding wire can result in the risk of electric shock. Check with a qualified electrician if you are in doubt as to whether the outlet is properly grounded. Do not modify the power cord plug provided with the product. Never remove the grounding prong from the plug. Do not use the product if the power cord or plug is damaged. If damaged, have it repaired by a service facility before use. If the plug will not fit the outlet, have a proper outlet installed by a qualified electrician.

GROUNDING PRODUCT: PRODUCTS WITH THREE PRONG PLUGS

1. Products marked with “Grounding Required” have a three wire cord and three prong grounding plug. The plug must be connected to a properly grounded outlet. If the product should electrically malfunction or break down, grounding provides a low resistance path to carry electricity away from the user, reducing the risk of electric shock. **(See Figure A.)**
2. The grounding prong in the plug is connected through the green wire inside the cord to the grounding system in the tool. The green wire in the cord must be the only wire connected to the product’s grounding system and must never be attached to an electrically “live” terminal. **(See Figure A.)**
3. Your product must be plugged into an appropriate outlet, properly installed and grounded in accordance with all codes and ordinances. The plug and outlet should look like those in the following illustration. **(See Figure A.)**

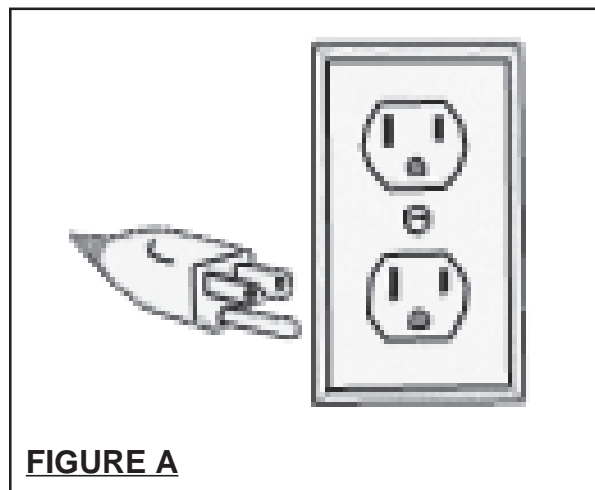
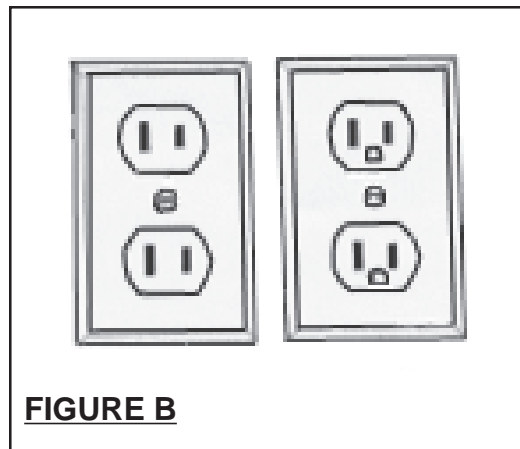

FIGURE A

DOUBLE INSULATED PRODUCTS: PRODUCTS WITH TWO PRONG PLUGS

4. Products marked “Double Insulated” do not require grounding. They have a special double insulation system which satisfies OSHA requirements and complies with the applicable standards of Underwriters Laboratories, Inc., the Canadian Standard Association, and the National Electrical Code. **(See Figure B.)**
5. Double insulated products may be used in either of the 120 volt outlets shown in the following illustration. **(See Figure B.)**



EXTENSION CORDS

1. **Grounded** tools require a three wire extension cord. **Double Insulated** tools can use either a two or three wire extension cord.
2. As the distance from the supply outlet increases, you must use a heavier gauge extension cord. Using extension cords with inadequately sized wire causes a serious drop in voltage, resulting in loss of power and possible product damage. **(See Figure C, next page.)**
3. The smaller the gauge number of the wire, the greater the capacity of the cord. For example, a 14 gauge cord can carry a higher current than a 16 gauge cord. **(See Figure C.)**
4. When using more than one extension cord to make up the total length, make sure each cord contains at least the minimum wire size required. **(See Figure C.)**
5. If you are using one extension cord for more than one product, add the name plate amperes and use the sum to determine the required minimum cord size. **(See Figure C.)**



6. If you are using an extension cord outdoors, make sure it is marked with the suffix "W-A" ("W" in Canada) to indicate it is acceptable for outdoor use.
7. Make sure your extension cord is properly wired and in good electrical condition. Always replace a damaged extension cord or have it repaired by a qualified electrician before using it.
8. Protect your extension cords from sharp objects, excessive heat, and damp or wet areas.

RECOMMENDED MINIMUM WIRE GAUGE FOR EXTENSION CORDS* (120 VOLT)					
NAMEPLATE AMPERES (At Full Load)	EXTENSION CORD LENGTH				
	25 Feet	50 Feet	75 Feet	100 Feet	150 Feet
0 – 2.0	18	18	18	18	16
2.1 – 3.4	18	18	18	16	14
3.5 – 5.0	18	18	16	14	12
5.1 – 7.0	18	16	14	12	12
7.1 – 12.0	18	14	12	10	-
12.1 – 16.0	14	12	10	-	-
16.1 – 20.0	12	10	-	-	-

FIGURE C * Based on limiting the line voltage drop to five volts at 150% of the rated amperes.

FIGURE C

SYMBOLOLOGY

	Double Insulated
	Canadian Standards Association
	Underwriters Laboratories, Inc.
V ~	Volts Alternating Current
A	Amperes
n_oxxxx/min.	No Load Revolutions per Minute (RPM)

UNPACKING

When unpacking, check to make sure all the parts shown on the **Parts List on page 12** are included. If any parts are missing or broken, please call Harbor Freight Tools at the number shown on the cover of this manual as soon as possible.

ASSEMBLY AND OPERATING INSTRUCTIONS

NOTE: For additional information regarding the parts listed in the following pages, refer to the **Assembly Diagram on page 13**.

CAUTION: Always make sure the Power Cord of the Air Filtration System is unplugged from its electrical outlet *prior* to making any adjustments to the product.

Note: If placing this Air Filtration System on a table or shelf, make sure that the machine is placed securely on a flat, level surface, capable of supporting the weight of the machine.

Note: If attaching the Air Filtration System to a ceiling, make sure the machine is attached securely to joists capable of supporting the weight of the machine.

1. Locate the desired ceiling location and ceiling joists, upon which to attach the Air Filtration System.
2. With assistance or lifting equipment (not included), raise the unit to the desired location. **Caution:** Make sure other people or pets are well clear of the area during this procedure.
3. Align the four Hangers (32) (see the *Assembly Drawing* on page 13) with the ceiling joists and measure for hook bolt location. Insert four hook bolts (not included) through the ceiling into the underside of the ceiling joists.

Note: The hook bolts must be capable of supporting the weight of the Air Filtration System, and be of compatible size with the Hangers (32). When hanging the unit, make sure each Hanger (32) fits completely over the end of each hook bolt to ensure a safe mounting of the Air Filtration System.

FIGURE 1

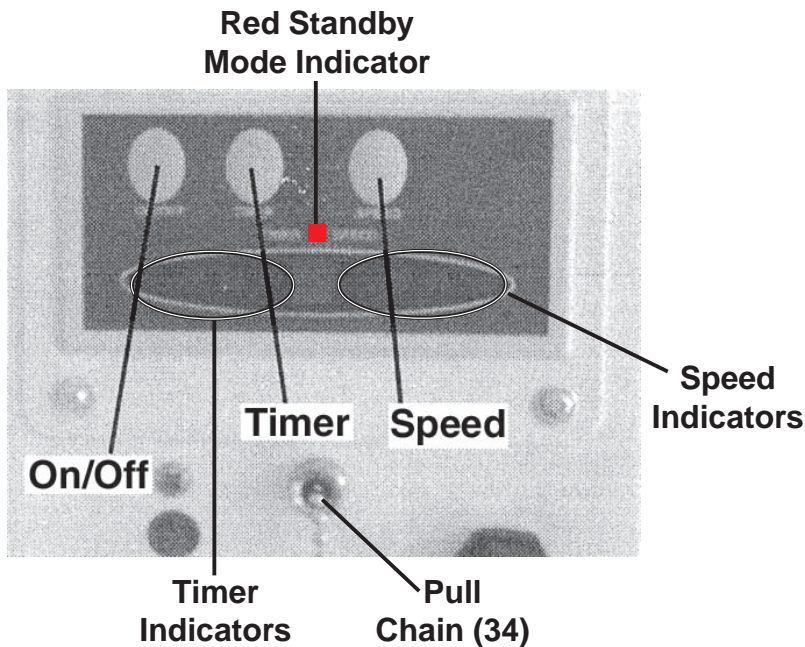
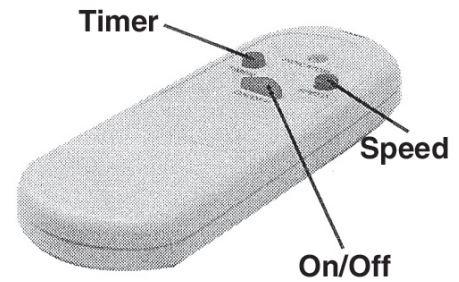

FIGURE 2



CONTROL OPERATION

Note: These instructions apply to both the manual controls and the remote control. See **Figures 1** and **2**.

1. The Pull Chain (34) under the control panel switches between standby mode and totally off. When in standby mode the unit will operate when the on/off button on the remote or the panel is pressed. The Chain may break if pulled hard or abruptly. This Chain may be used to stop the Air Filter System in the event of an emergency.
2. Press the "On/Off" button to activate the unit from standby mode. It switches on at high power initially.
3. Press the "Speed" button once for high power, twice for medium, and three times for low power. The three lights referred to as "Speed Indicators" in **Figure 1** indicate, from left to right; high, medium, and low speed.
4. Press the "Timer" button once for 2 hour automatic shut off, or twice for 4 hour automatic shut off. The three lights referred to as "Timer Indicators" in **Figure 1** indicate, from left to right; on continuously (no timer), 2 hour timer, and 4 hour timer.
5. The lights between the Speed and Timer Buttons indicate the speed that the unit is operating at. The faster the speed is the faster these lights flash.
6. To turn off the unit manually, press the Off button.

Note: To change batteries in the Remote Control (35); remove the back panel, replace the two "AAA" batteries, then replace the back panel.

INSPECTION, MAINTENANCE, AND CLEANING

1. **WARNING!** Make sure the Switch Box (19) of the Air Filtration System is in its "OFF" position and that the product is unplugged from its electrical outlet before performing any inspection, maintenance, or cleaning procedures.
2. **BEFORE EACH USE**, inspect the general condition of the Air Filtration System. Check for loose screws, misalignment or binding of moving parts, cracked or broken parts, damaged electrical wiring, and any other condition that may affect its safe operation. If abnormal noise or vibration occurs, have the problem corrected before further use. **Do not use damaged equipment.**
3. Periodically, inspect the Pleated Type Filter (1) for dirt and debris, and if necessary, remove and change the Pleated Type Filter (1). On the rear of the unit lift the Pleated Type Filter (1) so that its bottom edge clears the bottom lip of the opening. Swing the bottom out and remove the Pleated Type Filter (1) and inspect it to see whether it needs a simple cleaning, or it needs replacement. Reinsert the Pleated Type Filter (1). See **FIGURE 3**.

FIGURE 3

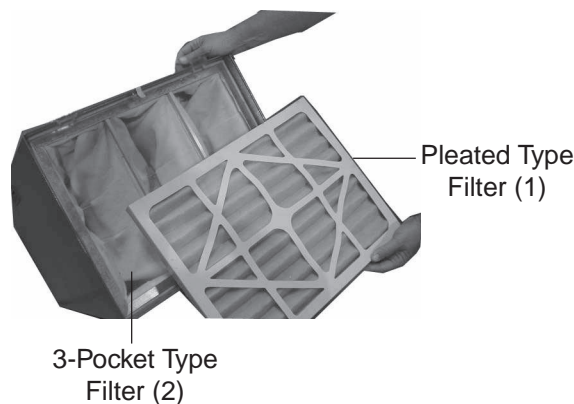

Note: During this procedure, wear ANSI approved safety goggles and a dust mask.

4. Periodically, inspect the 3-Pocket Type Filter (2) for dirt and debris, and if necessary, remove and change the 3-Pocket Type Filter (2). Remove the Pleated Type Filter (1), as explained above. Then, remove the 3-Pocket Type Filter (2) the same way and inspect it. If necessary, use compressed air to blow dirt and debris from the 3-Pocket Type Filter (2). Replace the 3-Pocket Type Filter (2) and the Pleated Type Filter (1) in the rear of the unit. See **FIGURE 3**.

Note: Replacement filters are available from Harbor Freight:

ITEM 91524 - Pleated Type Filter (also part 1)
ITEM 91516 - 3-Pocket Type Filter (also part 2)

Troubleshooting

Note: Any repairs suggested below should be completed by an authorized service technician.

Trouble	Probable Cause	Correction
Motor does not run when power switch is pressed on.	<ol style="list-style-type: none"> 1. Blown fuse. 2. Switch is burned out. 3. Connection wire is loose or damaged. 	<ol style="list-style-type: none"> 1. Replace fuse. 2. Replace the Switch. 3. Tighten or replace the wire.
Motor does not run at full speed.	<ol style="list-style-type: none"> 1. Power voltage is too low. 2. Motor is damaged. 	<ol style="list-style-type: none"> 1. Test voltage. 2. Check and repair motor.
Motor will not reach full power.	<ol style="list-style-type: none"> 1. Incorrect power wiring. 2. Overload. 	<ol style="list-style-type: none"> 1. Have the unit rewired professionally. 2. Reduce load by cleaning filters as necessary.
Motor overheats.	<ol style="list-style-type: none"> 1. Using wrong voltage. 2. Motor is damaged. 	<ol style="list-style-type: none"> 1. Verify that the outlet is 115 VAC. 2. Check and repair the motor.
Insufficient suction power.	<ol style="list-style-type: none"> 1. Inlet port blocked. 2. 3-Pocket Type Filter is full. 3. Outlet port blocked. 	<ol style="list-style-type: none"> 1. Clean inlet port. 2. Empty 3-Pocket Type Filter. 3. Clean the outlet port or adjust the direction of the outlet.
Unit is shaking.	<ol style="list-style-type: none"> 1. The unit isn't properly anchored. 2. The unit isn't level. 3. Worn or damaged power cord. 	<ol style="list-style-type: none"> 1. Mount the unit firmly. 2. Level the unit. 3. Repair or replace power cord.

PARTS LIST

Part	Description	Qty.	Part	Description	Qty.
1	Pleated Type Filter	2	20	Round Head Screw	4
2	3-Pocket Type Filter	2	21	Hex Screw	6
4	Cross Head Screw	8	22	Safety Net	1
5	Fan Housing	1	23	Outlet Grill	1
6	Fan Blade	1	24	Screw	2
7	Air Guide Plate	2	27	Hex Head Screw	16
8	Power Cord	1	28	Round Head Screw	2
10	Nut	1	29	Washer	4
12	Bushing	1	30	Nut	4
13	Condenser	1	31	Handle	2
14	Motor	1	32	Hanger	4
15	Bushing	4	33	Nut	4
16	Set Screw	1	34	Pull Chain	1
17	Main Cabinet	1	35	Remote Control	1
18	Receiver	1	36	Rubber Pad	4
19	Switch Box	1			

PLEASE READ THE FOLLOWING CAREFULLY

THE MANUFACTURER AND/OR DISTRIBUTOR HAS PROVIDED THE PARTS LIST AND ASSEMBLY DIAGRAM IN THIS MANUAL AS A REFERENCE TOOL ONLY. NEITHER THE MANUFACTURER OR DISTRIBUTOR MAKES ANY REPRESENTATION OR WARRANTY OF ANY KIND TO THE BUYER THAT HE OR SHE IS QUALIFIED TO MAKE ANY REPAIRS TO THE PRODUCT, OR THAT HE OR SHE IS QUALIFIED TO REPLACE ANY PARTS OF THE PRODUCT. IN FACT, THE MANUFACTURER AND/OR DISTRIBUTOR EXPRESSLY STATES THAT ALL REPAIRS AND PARTS REPLACEMENTS SHOULD BE UNDERTAKEN BY CERTIFIED AND LICENSED TECHNICIANS, AND NOT BY THE BUYER. THE BUYER ASSUMES ALL RISK AND LIABILITY ARISING OUT OF HIS OR HER REPAIRS TO THE ORIGINAL PRODUCT OR REPLACEMENT PARTS THERETO, OR ARISING OUT OF HIS OR HER INSTALLATION OF REPLACEMENT PARTS THERETO.

ASSEMBLY DIAGRAM

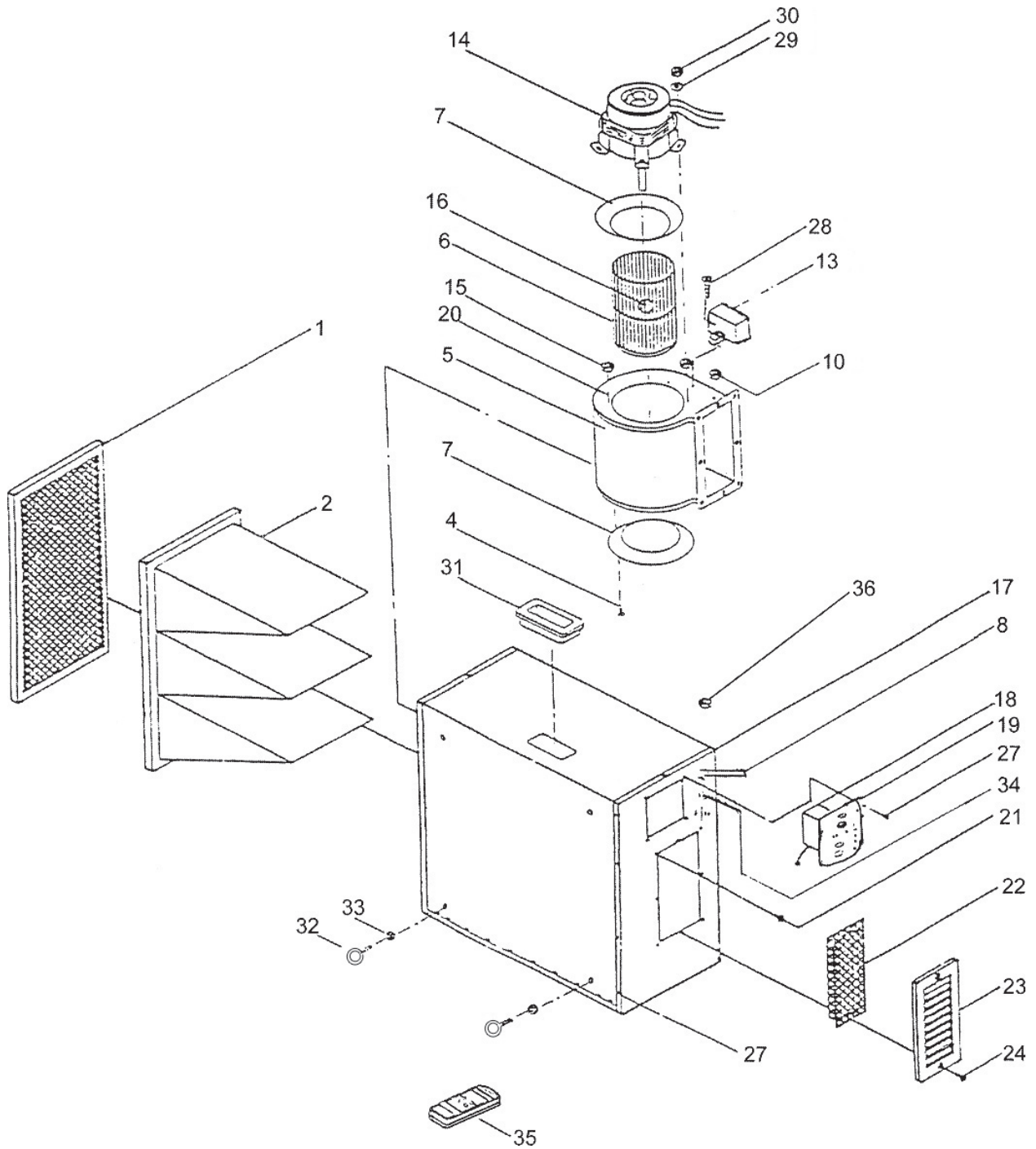

NOTE: Some parts are listed and shown for illustration purposes only, and are not available individually as replacement parts.